

Ficha técnica

Presor central para fijar paneles uno con otro

S11B

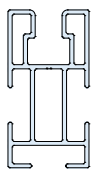
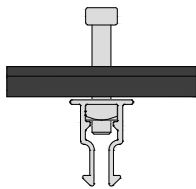
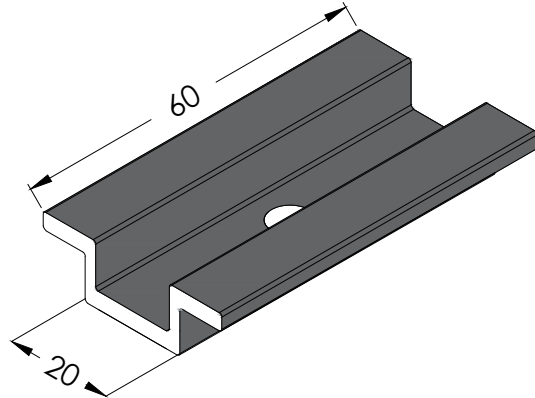
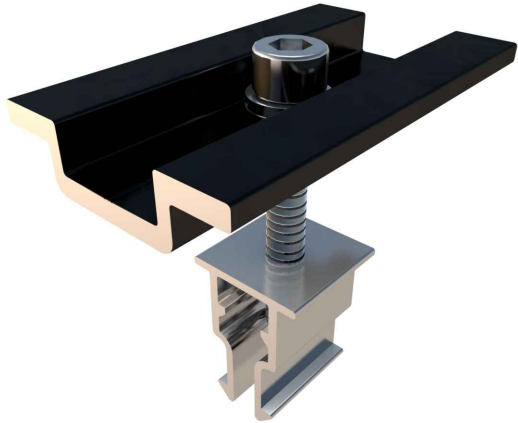

1)

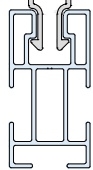
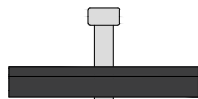

2)

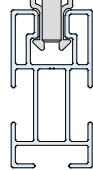

3)

- 1) Alinear presor con el perfil
- 2) bajar hasta hacer clic
- 3) roscar el tornillo.

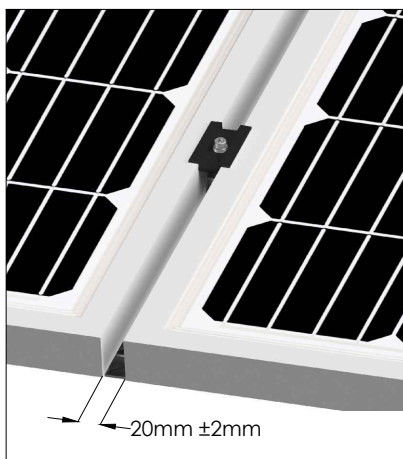

Válido para medidas de espesor de módulo de 30 mm a 45 mm. Para espesores diferentes solicitar bajo pedido.

Materiales: Perfilería de aluminio EN AW 6005A T6
Acabado en anodizado negro
Tornillería de acero inoxidable A2-70



Debido a que esta pieza tiene un acabado en negro y un embalaje a granel puede presentar algún rasguño superficial. Esto no será motivo de devolución.

Herramientas necesarias:



Par de apriete:
Tornillo Presor 7 Nm

Seguridad:



Marcado ES19/86524 CE